

Manual

Series E16521D

(Revision 13)

Original Instructions
valid for E16521D.1/E16521D.4 and E16521D.2 and E16521D.3



E16521D Front View
(version E16521D.1 is shown)

**Single Channel Speed Monitor
for
increased safety requirements up to SIL2**

Table of Contents

Content	Page
Table of Contents	2
1 Technical Specifications	3
1.1 Dimensions.....	5
2 Description	6
2.1 Function	6
2.2 Display and Operating Elements	6
2.3 Display	6
2.3.1 Display of Sensor Signal Level (only with E16521D.1 and E16521D.2).....	6
2.4 Status LEDs.....	6
2.5 Functions during normal operation	7
2.6 Display of Firmware Release State and CRC-Parameter-Checksum.....	7
2.7 Event Codes on Display	7
2.8 Measuring Principle.....	7
2.9 Performance at Signal Break.....	7
2.10 Input Starter.....	7
2.11 Input Reset.....	7
2.12 Setpoint SP1 with Safety Output OR1.....	8
2.13 Setpoints SP2 with OR2, SP3 with OR3, SP4 with OR4	8
2.14 Analog Output	8
2.15 Pulse Repeating Output	8
2.16 Response Time of Safety Output OR1 to Trip Condition	8
3 Parameters	9
3.1 Summary of parameters and their default values as set on delivery	9
3.2 Setting the Parameters via Interface	10
3.2.1 Setting the Parameters via USB 2.0 Interface (from serial number 2011250001)	10
3.2.2 Setting the Parameters via RS232 Interface (up to serial number 2011249999)	10
3.3 Setting the parameters via Front Keyboard (not with E16521D.4)	11
4 Description of Parameters and their Settings	12
4.1 Default Values	20
5 Safety Notes for Installation and Operation	21
5.1 Safety Notes for Installation.....	21
5.1.1 General Instructions.....	21
5.1.2 EMI	21
5.1.3 Safety Notes for Operation	21
5.1.4 Connectors	21
5.2 Safety Notes for SIL2 Speed applications	22
5.2.1 Monitoring the Speed Signal.....	22
5.2.2 Use of the Safety Output OR1	22
5.3 Safety Data of E16521D.....	22
6 Wiring of E16521D	23
6.1 Function Diagram and Terminals of E16521D.....	23
6.2 Connection of Sensors to the Speed Signal Input	24
6.3 Example for 2oo3 Wiring of Safety Outputs OR1	25
7 Revision notes	26

Design	Dimensions: see chapter Dimensions Weight: standard version approx. 0.3 kg, option –G approx. 1.0 kg
Installation Conditions	Ambient temperature in operation: 0°C...+60°C Ambient temperature in storage: -40°C...+85°C Electrical insulation grade: I Voltage grade: I Protection grade standard version:..... terminals IP20, enclosure IP40 Protection grade option -G: IP65
Power Supply	Supply voltage: 20...265 Vuc for model E16521D.2U1: 18...40 Vuc Power consumption:5 W resp. 5 VA
E16521D.1/E16521D.4 Signal Input and Supply for BRAUN A5S... Sensors	Input frequency: 0,1 Hz...50 kHz Max. signal voltage:..... 30 V Response levels:.....high at > 6.5 V, low at < 4 V Sensor supply: approx. 13 V, max. 60 mA
E16521D.2 Signal Input and Supply for EC Sensor	Input frequency: 0,1 Hz...50 kHz Max. signal voltage:..... 30 V Trigger hysteresis:..... 0.07 to 2.5 V pp Sensor supply: approx. 24 V, max. 40 mA for model E16521D.2U1: approx. 24 V, max. 120 mA
E16521D.3 Signal input for MPU	Input frequency: 5 Hz...50 kHz Max. signal voltage:..... 60 Vpp Trigger hysteresis:..... 0.07 to 2.5 Vpp Max. impedance MPU: 4 kohms
Measurement	Accuracy: ± 0.005 % of measurement, ± 1 in LSD
Pulse Output	Repeating the input signal, isolated and push/pull with approx. 20 volts level
Relay Outputs	OR1 as DPST, OR2 as SPST, OR3 and OR4 as PhotoMos (SPST) Contact rating of OR1 and OR2:

Electrical endurance	at 12 V / 10 mA	typ. 5 x 10 ⁷ operations
	at 6 V / 100 mA	typ. 1 x 10 ⁷ operations
	at 60 V / 500 mA	typ. 5 x 10 ⁵ operations
	at 30 V / 1000 mA	typ. 1 x 10 ⁶ operations
	at 30 V / 2000 mA	typ. 2 x 10 ⁵ operations
Mechanical endurance		typ. 10 ⁸ operations
UL contact ratings		220 Vdc / 0.24 A - 60 W
		125 Vdc / 0.24 A - 30 W
		250 Vac / 0.25 A - 62.5 VA
		125 Vac / 0.5 A - 62.5 VA
		30 Vdc / 2 A - 60 W

(inductive loads need external spark extinguishing device)

Contact rating of OR3 and OR4: 60 Vdc / 0.1 A / 3 W (typ. 5 x 10⁷ operations)

Analog output

Isolated and programmable with range 0/4 .. 20 mA

Resolution: 12 bit

Max. load:..... 500 ohms

Linearity error: < 0.1 %

Temperature stability: ± 0.02 %/°C within a range of 0...60 °C

Display

(not with E16521D.4)

5 digits LED red, 10 mm, with adjustable decimal point

Programming Interface

with interface software IS-RS232-S and

RS232 up to serial number 2011249999:

with cable L3D01 for PC with RS232

USB2.0 from serial number 2011250001:

with cable L3D07 for PC with USB-A or

with cable L3D08 for PC with USB-C

1.1 Dimensions

Dimensions (mm) of snap-on-track (standard) version

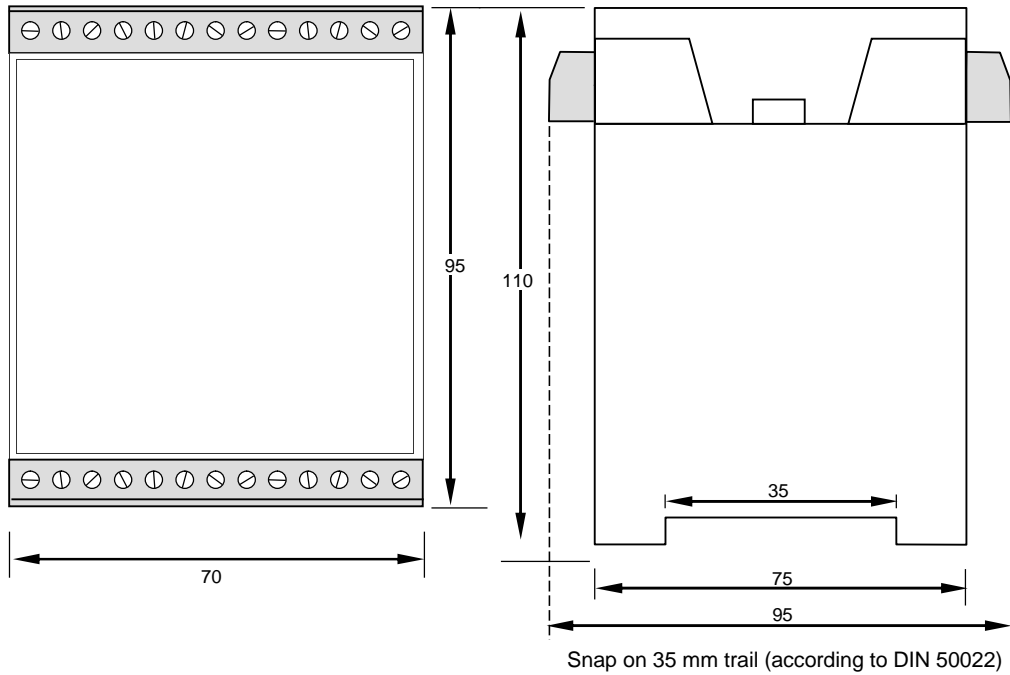

Dimensions of Field Mounting Enclosure (Option -G)

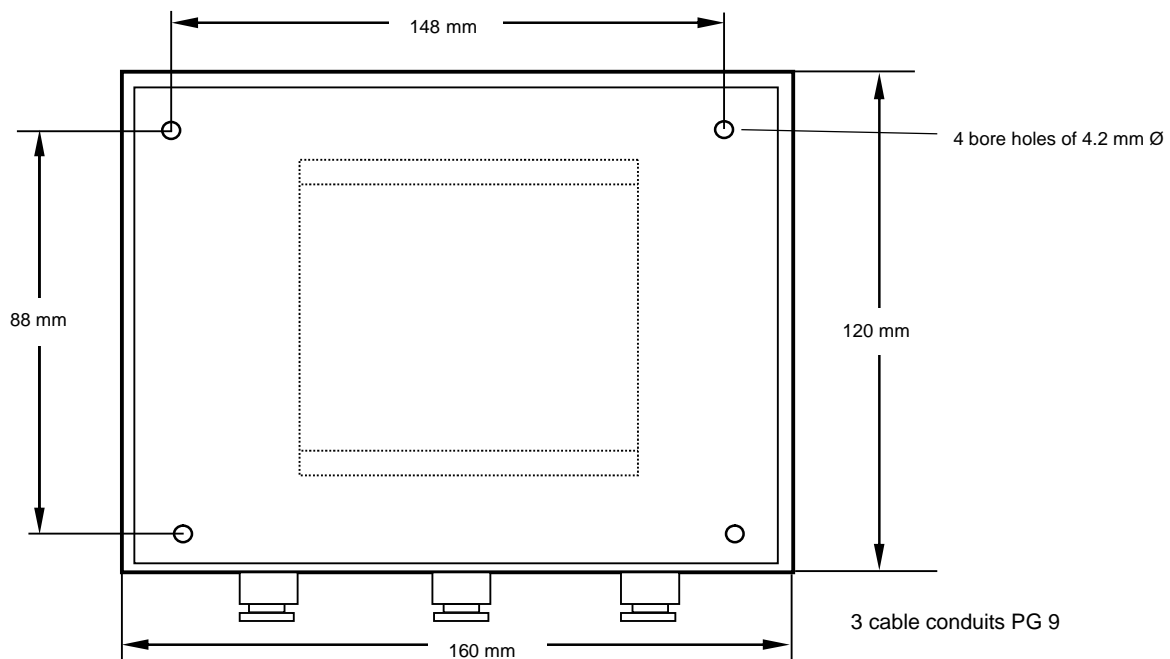

2 Description

2.1 Function

The device measures the speed of rotating equipment such as turbines, compressors or expanders and monitors it versus setpoints and converts it into an analog output. Parameters may be set via front keyboard and display or via the USB2.0 data interface.

2.2 Display and Operating Elements

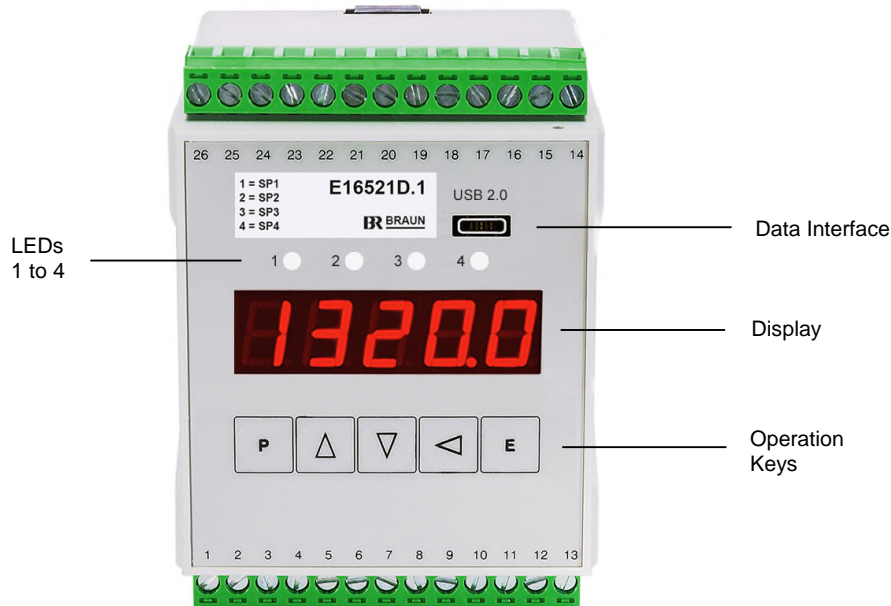

Note: E16521D.4 does not have LEDs, keys and display.

2.3 Display

During normal operation, the speed will be displayed.

2.3.1 Display of Sensor Signal Level (only with E16521D.1 and E16521D.2)

This function exists for units with serial nos > 2307210050 respective firmware date D.02.08.23. By pressing simultaneously of keys Δ and ∇ for 6 seconds the display is shifted to the value of the measured sensor signal level.

With key Δ the measured maximum value of the signal is displayed.

With key ∇ the measured minimum value of the signal is displayed.

Maximum and minimum values are updated each second.





During display of sensor signal level LED4 is blinking.

Return to display of speed value by pressing again simultaneously of keys Δ and ∇ for 6 seconds.



2.4 Status LEDs

LEDs 1 to 4 are on if the corresponding output relays OR1 to OR4 are energized.

2.5 Functions during normal operation

Key  : Reset of latched max./min. speed values
Key  : Display of latched max. speed value
Key  : Display of latched min. speed value
Keys  and  : Reset of latched alarms

2.6 Display of Firmware Release State and CRC-Parameter-Checksum

With key  pressed longer as 5 seconds, the firmware release state and the CRC-Parameter-Checksum will be shown in a scrolled display (as long as  is pressed).

A.0456 (firmware ID)
U.___xx (xx = firmware version number)
D.uu__ (uu = day)
D._vv_ (vv = month)
D.___ww (ww = year of firmware release state)
C.abcd (abcd = CRC-Parameter-Checksum)

2.7 Event Codes on Display

-E1- : Wrong code figure in step P00.00
SE-01 : Sensor fault or signal lead break

2.8 Measuring Principle

Measurement is based on the frequency of the pulse sequence representing the speed. Basic quantity is the time between one or more of its pulses. An automatic function determines this number, in order to maintain a minimum period of time for every measurement to be extended over. This time minimum is programmable to 5 milliseconds or more, thus establishing a corresponding averaging and stabilization of measurements.

The corresponding speed value in terms of RPM, by which the display, the alarms and the analog output are reading, computes from these measurements. This process further considers the programmed application data (relation between machine speed and signal frequency).

2.9 Performance at Signal Break

In normal operation, the function closely tracks the input sequence, with the programmed performance. After a sudden interrupt of the input pulses, the unit reduces the readings following an automatic step-down sequence. This starts as fast as the most recent measuring sequence before interrupt but then decreases slower and slower (reciprocal) until it meets the programmed low end.

2.10 Input Starter

As long as the input Starter is true, the enabled setpoints will be put to their assigned relay state.

Note:

A positive edge at the input Starter will reset latched alarms.

2.11 Input Reset

A positive edge at the input Reset will reset latched alarms.

The input Reset must be actuated once after power up of the Monitor (if parameter P01.07 = 0).

if:

- power has failed and returns at speed < SP2 and input Starter is still true
- power has failed and returns at speed > SP2 and input Starter is still true or not true

2.12 Setpoint SP1 with Safety Output OR1

SP1 has individually programmable response characteristics.
OR1 has two SPDT relays connected in series.
OR1 can be programmed to respond also to SP2.

2.13 Setpoints SP2 with OR2, SP3 with OR3, SP4 with OR4

Each with individually programmable response characteristics, and each with programmable starter.

2.14 Analog Output

Output signal isolated and linear as current 0/4... 20 mamps into 500 Ohms max load.
Live zero as well as high and low end of conversion programmable.

2.15 Pulse Repeating Output

Push/pull with approx. 20 volts level, isolated versus signal input and versus power supply.
Repeating the input pulse signals by the same sequence.

2.16 Response Time of Safety Output OR1 to Trip Condition

The response time of the Safety Output OR1 to Trip Condition is less than 15 ms (at a minimum measurement time of 5 milliseconds).

3 Parameters

3.1 Summary of parameters and their default values as set on delivery

Param. No.	Default Value	Parameter Function
P00.xx		Code Figure, Parameter Lock, Minimum Measuring Period
P00.00	0000	Code figure
.01	0000	New code figure
.02	1	Front side Parameter Lock : 0 : yes / 1 : no
.03	0005	Minimum Measuring Period: 0005 ... 9999 [ms]
.04	000	Starter Time Period in xxx [s]
P01.xx		Measurement Configuration, Reset, Sensor Monitoring
P01.00	0	Fix value 0
.01	10000	Nominal input frequency in [Hz]
.02	0	Fix value 0
.03	10000	Nominal speed in [RPM]
.04	00001	Low end of the speed measurement in [RPM]
.05	0	Reserved
.06	0	Reserved
.07	0	Reset necessary after power up: 0 : yes / 1 : no
.08	1	Sensor monitoring: 0 : off / 1 : on / 2 : on, latched
.09	0	Mode of sensor monitoring: see parameter description
.10	001	Fix value 001
P02.xx		Display
P02.00	0	Fix value 0
.01	0.3	Display updating sequence in x.x [s]
P03.xx		Analog Output
P03.00	10000	High end of analog output at speed in [RPM]
.01	00000	Low end of analog output at speed in [RPM]
.02	1	Zero level: 0 : dead zero / 1 : live zero
.03	1	Fix value 1
.04	0	Output level at sensor fault: 0 : no change / 1 : min / 2 : max
.05	0	Output direction: 0 : 0/4...20 [mA] / 1 : 20...4/0 [mA]
P04.xx		Speed Setpoint SP1 and Safety Output OR1
P04.00	01000	Speed setpoint SP1 in [RPM]
.01	05.0	Hysteresis bandwidth SP1: 00.1...99.9 %
.02	0	Hysteresis position: 0 : above SP1 / 1 : below SP1
.03	1	De-energized state OR1 at 'n > SP1' or 'n < SP1': see parameter description
.04	0	OR1 also at 'n < SP2': 0 : no, 1 : yes
.05	0	Reserved
.06	0	OR1 forced state at sensor fault: see parameter description
		Continued on next page

Param. No.	Default Value	Parameter Function
P05.xx		
Speed Setpoint SP2 and Alarm Output OR2		
P05.00	01100	Speed setpoint SP2 in RPM
.01	05.0	Hysteresis bandwidth SP2: 00.1....99.9 %
.02	0	Hysteresis position: 0 : above SP2 / 1 : below SP2
.03	1	De-energized state OR2 at ' n > SP2 ' or ' n < SP2 ' : see parameter description
.04	1	Starter effective for SP2: 0 : no / 1 : yes
.05	1	OR2 state at starter condition: 0 : de-energized / 1 : energized
.06	0	OR2 forced state at sensor fault: see parameter description
P06.xx		
Speed Setpoint SP3 and Alarm Output OR3		
P06.00	01200	Speed setpoint SP3 in RPM
.01	05.0	Hysteresis bandwidth SP3: 00.1....99.9 %
.02	0	Hysteresis position: 0 : above SP3 / 1 : below SP3
.03	1	De-energized state OR3 at ' n > SP3 ' or ' n < SP3 ' : see parameter description
.04	1	Starter effective for SP3: 0 : no / 1 : yes
.05	1	OR3 state at starter condition: 0 : de-energized / 1 : energized
.06	0	OR3 forced state at sensor fault: see parameter description
P07.xx		
Speed Setpoint SP4 and Alarm Output OR4		
P07.00	01300	Speed setpoint SP4 in RPM
.01	05.0	Hysteresis bandwidth SP4: 00.1....99.9 %
.02	0	Hysteresis position: 0 : above SP4 / 1 : below SP4
.03	1	De-energized state OR4 at ' n > SP4 ' or ' n < SP4 ' : see parameter description
.04	1	Starter effective for SP4: 0 : no / 1 : yes
.05	1	OR4 state at starter condition: 0 : de-energized / 1 : energized
.06	0	OR4 forced state at sensor fault: see parameter description
P08.xx		
Eddy current (EC) and MPU sensor		
P08.00	00.0	EC sensor input check: input voltage upper limit in xx.x [volts]
.01	00.0	input voltage lower limit in xx.x [volts]
.02	00.0	current drain upper limit in xxx [mA]
.03	00.0	current drain lower limit in xxx [mA]
.04	0.0	EC and MPU sensor input hysteresis in x.x volts
.05	0	Reserved
P09.xx		
Data interface		
P09.00	4	Baudrate: 0 : 300 / 1 : 1200 / 2 : 9600 / 3 : 19200 / 4 : 38400 Baud
.01	008	Reserved

3.2 Setting the Parameters via Interface

3.2.1 Setting the Parameters via USB 2.0 Interface (from serial number 2011250001)

Only possible for OEM with special interface software IS-RS232-E16 from BRAUN and USB adapter cable L3D07 (for PC with USB-A) resp. L3D08 (for PC with USB-C).

3.2.2 Setting the Parameters via RS232 Interface (up to serial number 2011249999)

Only possible for OEM with special interface software IS-RS232-E16 from BRAUN and adapter cable L3D01 (PC must have a 9pole SUB-D RS232 Interface).

3.3 Setting the parameters via Front Keyboard (not with E16521D.4)

Principle: Select a parameter via its ,name' **Pgg.ss**,
 in that **gg** : Parameter-group number and
ss : Step-number within the group,

then display the value and alter if required.

Procedure:

Initiate programming phase by pressing keys **P** and **E** together;

instead of the normal display P00.00. appears

Select the group or step number with keys **Δ**, **∇**.

Switch between Groups and Step Fields with the **◀**. key

Current value of the Parameters is displayed with key **E**.

Select active position with the **◀**. key

Adjust the number in the active field with keys **Δ**, **∇**.

Acknowledge and set with key **E**, Discard (original value remains) with key **P**.

Return to operational mode with the **P** key.

See example below: Change parameter P01.01 from 2386 to 2387 or 2385.

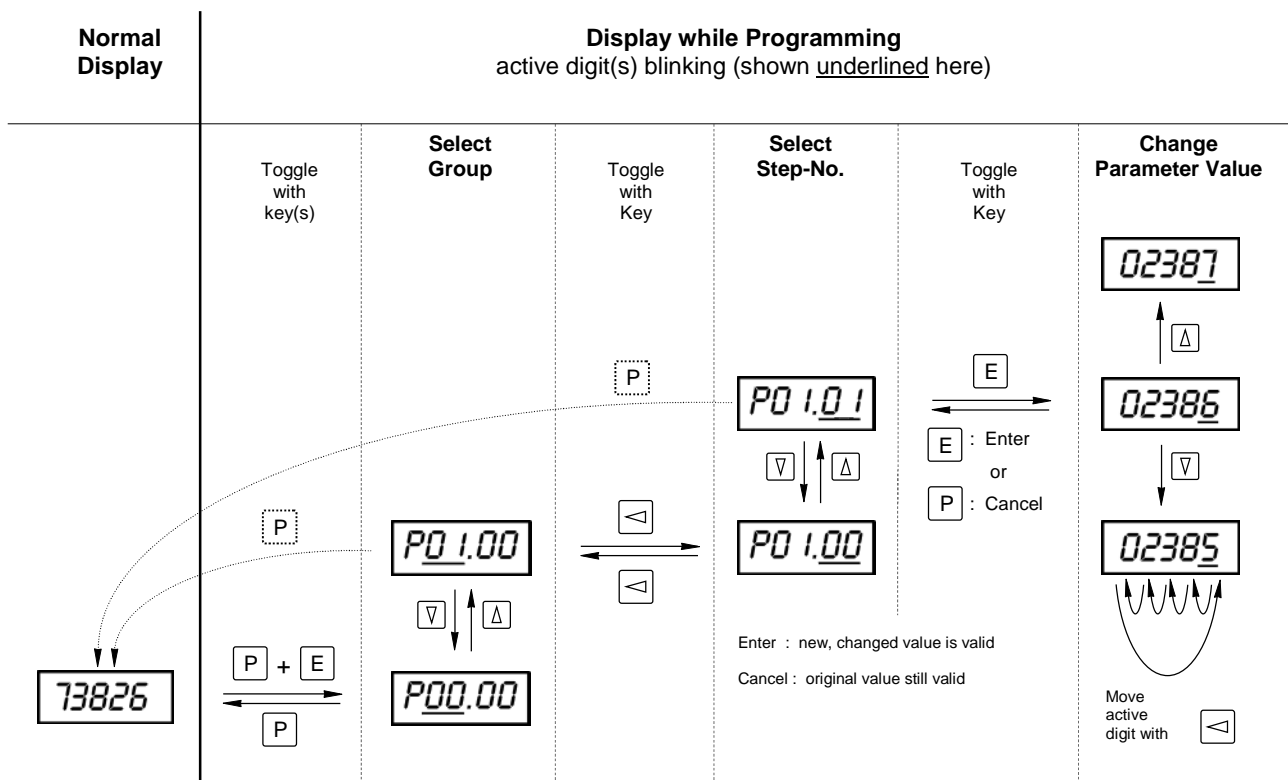

Parameter Group P00.xx Code Figure, Parameter Lock, Front side Reset of Alarms	
Parameter No. Meaning of Parameter Setting Range of Parameter	Description of Parameters and their Settings
P00.00 Code Figure Range: 0000 .. 9999	If the parameters are locked (see P00.02), the code figure must be entered prior to any change of other parameters. If the code figure is not correct, -E 1- is displayed. Without code figure and P00.02 = 0 the values of all parameters may be inspected, but not changed.
P00.01 New Code Figure Range: 0000 .. 9999	A new code figure may be set in P00.01. Then it replaces the previous one.
P00.02 Front side Parameter Lock Range: 0 .. 1	Setting: 0 : Parameters are locked, front side change only possible with code figure 1 : Parameters unlocked, front side change of parameter values possible
P00.03 Minimum Measuring Period in milliseconds Range: 0005 .. 9999	The measurement is based on a time interval measurement over a (variable) number of input signal pulses. A programmable minimum measuring period thus will be maintained, automatically including more input pulses into every measurement with increasing input frequency. This establishes an averaging over the programmed period of time, which helps to stabilize the measurements, specifically with fluctuating variables. The setting of P00.03 defines the minimum measuring period of time, in terms of milliseconds, within a range of 0005....9999 milliseconds. A setting less than 0005 is possible, but minimum measuring time will still be 5 msec.
P00.04 Starter Time Period Range: 000 .. 999	This step sets the starter time period (duration) in terms of seconds. The starter condition state lasts from the beginning of the external starter signal plus the programmed time elapse following its end. Valid for all setpoints with the activated starter.

Parameter Group P01.xx Measurement Configuration	
Parameter No. Meaning of Parameter Setting Range of Parameter	Description of Parameters and their Settings
P01.01 and P01.03: Scaling	<p>Scaling defines the relation between the input signal frequency (in terms of Hz), and the corresponding display (e.g. in RPM and decimal position required by the application). Both values are freely programmable by their decimals and numerical amount. Of course, they must refer to the same operation level. This reference point is recommended close to the high end of the intended operation range. In later operation, however, it may be overrun without error.</p> <p>Example: A rotating shaft to be measured carries 36 slots. At a shaft speed of 1500 RPM, this produces a signal frequency of 1500×36 pulses per minute = 54,000 pulses per minute = $54,000 \div 60$ Hz = 900 Hz. (Presuming the prediver is set to 001). Therefore, 900 (Hz) and 1500 (m/min) are the data-set to be programmed in the corresponding program steps: Step P01.01 : parameter = 00900 P01.03 : parameter = 01500.</p>
P01.00 Fix value 0	
P01.01 Nominal Input frequency in Hz Range: 00001 .. 99999	
P01.02 Fix value 0	
P01.03 Nominal Speed in RPM Range: 00001 .. 99999	
P01.04 Low end of speed measurement in RPM Range: 00001 .. 99999	If the speed falls lower than this level, the measurement will be canceled to zero even if the machine still turns with a speed lower than 1 RPM (at value of 00001).
P01.05 Reserved	
P01.06 Reserved	

Parameter Group P01.xx (continued) Reset, Sensor Monitoring	
Parameter No. Meaning of Parameter Setting Range of Parameter	Description of Parameters and their Settings
P01.07 Reset necessary after power up Range: 0 .. 1	Depending on this setting, the Reset input must be actuated once after power up of the Monitor to enable operation. 0 : Reset necessary (recommended setting for safety applications) 1 : Reset not necessary Note: a positive edge of the Starter signal also acts as Reset
P01.08 Sensor monitoring on/off Range: 0 .. 2	If the sensor is monitored, the fault alarm may be latched until it is reset. Setting: 0 : off (sensor monitor disabled) 1 : on, not latched (not recommended for E16521D.2, see Note 2) 2 : on, latched Note 1: If P01.08 set to 0 , Step P01.09 is meaningless. Note 2: With E16521D.2 setting 1 should be used only for test purposes during commissioning, otherwise relay chatter may occur if threshold of alarm level is crossed.
P01.09 Mode of sensor monitoring Range: 0 .. 7	Setting: 0 : Without monitoring (see Note 3) 1 : Checks sensor current drain (E16521D.1) 2 : Checks signal voltage level at standstill (E16521D.1, see Note 4) 3 : Current drain and voltage level (E16521D.1, see Note 4) 4 : Inductive sensor (E16521D.3, see Note 5) 5 : Reserved for future use 6 : Eddy Current sensor voltage level (E16521D.2, see Note 6) 7 : Eddy Current sensor voltage level and current drain (E16521D.2, see Note 6) Note 3: Selection of Setting 0 makes Step P01.08 meaningless. Note 4: The voltage level check is only possible with BRAUN-sensor type A5S... . In this instance, even at a standstill a defective sensor or supply cable can be detected. Note 5: The response time for open loop detection is 0,6 seconds. Note 6: The signal voltage level (and current drain) is compared versus max/min-values as set in P08.00 to P08.03.
P01.10 Fix value 001	

Parameter Group P02.xx Display	
Parameter No. Meaning of Parameter Setting Range of Parameter	Description of Parameters and their Settings
P02.00 Fix value 0	
P02.01 Display updating sequence Range: 0.1 .. 9.9	Independent from the response time used for other functions, the display may have its own up-dating sequence - again in the interest of stabilized and well legible readings. Set the time between updates in steps of 0.1 sec. A recommended value is 0.3 sec.

Parameter Group P03.xx Analog Output	
Parameter No. Meaning of Parameter Setting Range of Parameter	Description of Parameters and their Settings
P03.00 High end of analog output at speed Range: 00001 .. 99999	The high end defines at which speed (RPM) the output delivers 20 mamps.
P03.01 Low end of analog output at speed Range: 00001 .. 99999	The low end defines at which speed (RPM) the output delivers 0 resp. 4 mamps.
P03.02 Live Zero Range: 0 .. 1	The analog signal can be without or with live zero. Setting: 0 : "without live zero" = 0...20 mA 1 : "with live zero" = 4...20 mA
P03.03 Fix value 1	
P03.04 Forced output level at sensor fault condition Range: 0 .. 2	Setting: 0 : no, output follows measured speed 1 : min: output goes to < 0 mamps 2 : max: output goes to approx. 21 mamps
P03.05 Output direction Range: 0 .. 1	Setting: 0 : normal (0/4 ..20 mA with increasing speed) 1 : inverted (20...0/4 mA with increasing speed)

Parameter Group P04.xx Speed Setpoint SP1 and Safety Output OR1	
Parameter No. Meaning of Parameter Setting Range of Parameter	Description of Parameters and their Settings
P04.00 Speed setpoint SP1 Range: 00001 .. 99999	Speed setpoint SP1 is set in RPM.
P04.01 Hysteresis bandwidth SP1 Range: 00.1 .. 99.9	The hysteresis is the margin between condition "excess" (>) and "no excess" (<), defined by its bandwidth. The hysteresis bandwidth is set as a percentage of the setpoint in steps of 0.1%.
P04.02 Hysteresis position SP1 Range: 0 .. 1	Setting: 0 : hysteresis above SP1 (recommended when monitoring $n < SP1$) 1 : hysteresis below SP1 (recommended when monitoring $n > SP1$)
P04.03 De-energized state OR1 at 'n > SP1' or 'n < SP1' Range: 0 .. 3	Without power supply the relays are de-energized (alarm condition). To consider safety aspects of the application, this No-Power condition can be assigned to alarm state $n > SP1$ or $n < SP1$ condition. Setting: 0 : OR1 de-energized at ' $n < SP1$ ' 1 : OR1 de-energized at ' $n > SP1$ ' 2 : OR1 de-energized and latched at ' $n < SP1$ ' 3 : OR1 de-energized and latched at ' $n > SP1$ '
P04.04 OR1 also at 'n < SP2' Range: 0 .. 1	If P04.03 is set to 1 or 3, the Safety Output OR1 responds not only to $n > SP1$ but also to $n < SP2$ (to SP2 only if the starter condition is not true). Setting: 0 : OR1 is assigned to state of SP1 only 1 : OR1 is assigned to state of SP1 and SP2 Note: If P04.04 = 1 then <ul style="list-style-type: none"> • P04.02 must be set to 1 • value of P05.00 must be lower than value of P04.00 • P05.02 must be 0 • P05.03 must be 0 or 2
P04.05 Reserved	
P04.06 OR1 in forced de-energized state at sensor fault condition Range: 0 .. 2	At sensor fault, OR1 may be forced to de-energized state. Setting: 0 : no forced state, state acc. to measured speed 1 : OR1 in de-energized state as if $n > SP1$ (if P04.03 is 1 or 3) 2 : OR1 in de-energized state as if $n < SP1$ (if P04.03 is 0 or 2)

Parameter Group P05.xx Speed Setpoint SP2 and Alarm Output OR2	
Parameter No. Meaning of Parameter Setting Range of Parameter	Description of Parameters and their Settings
P05.00 Speed setpoint SP2 Range: 00001 .. 99999	Speed setpoint SP2 is set in RPM.
P05.01 Hysteresis bandwidth SP2 Range: 00.1 .. 99.9	The hysteresis is the margin between condition "excess" (>) and "no excess" (<), defined by its bandwidth. The hysteresis bandwidth is set as a percentage of the setpoint in steps of 0.1%.
P05.02 Hysteresis position SP2 Range: 0 .. 1	Setting: 0 : hysteresis above SP2 (recommended when monitoring $n < SP2$) 1 : hysteresis below SP2 (recommended when monitoring $n > SP2$)
P05.03 De-energized state OR2 at ' $n > SP2$ ' or ' $n < SP2$ ' Range: 0 .. 3	Without power supply the relays are de-energized (alarm condition). To consider safety aspects of the application, this No-Power condition can be assigned to alarm state $n > SP2$ or $n < SP2$ condition. Setting: 0 : OR2 de-energized at ' $n < SP2$ ' 1 : OR2 de-energized at ' $n > SP2$ ' 2 : OR2 de-energized and latched at ' $n < SP2$ ' 3 : OR2 de-energized and latched at ' $n > SP2$ '
P05.04 Starter effective for SP2 Range: 0 .. 1	The starter function may be effective for each setpoint individually. Thereby it is possible, for instance, to disable a low-speed alarm during the starter phase, whereas a high-speed alarm remains active all the time. Setting: 0 : starter not effective for setpoint SP2 1 : starter effective for setpoint SP2
P05.05 OR2 state at starter condition Range: 0 .. 1	At starter condition, the relay may be forced to state energized or de-energized (if starter function is effective for the alarm). Setting: 0 : OR2 de-energized 1 : OR2 energized
P05.06 OR2 in forced de-energized state at sensor fault condition Range: 0 .. 2	At sensor fault, OR2 may be forced to de-energized state. Setting: 0 : no forced state, state acc. to measured speed 1 : OR2 in de-energized state as if $n > SP2$ (if P05.03 is 1 or 3) 2 : OR2 in de-energized state as if $n < SP2$ (if P05.03 is 0 or 2)

Parameter Group P06.xx Speed Setpoint SP3 and Alarm Output OR3	
Parameter No. Meaning of Parameter Setting Range of Parameter	Description of Parameters and their Settings
P06.00 Speed setpoint SP3 Range: 00001 .. 99999	Speed setpoint SP3 is set in RPM.
P06.01 Hysteresis bandwidth SP3 Range: 00.1 .. 99.9	The hysteresis is the margin between condition "excess" (>) and "no excess" (<), defined by its bandwidth. The hysteresis bandwidth is set as a percentage of the setpoint in steps of 0.1%.
P06.02 Hysteresis position SP3 Range: 0 .. 1	Setting: 0 : hysteresis above SP3 (recommended when monitoring $n < SP3$) 1 : hysteresis below SP3 (recommended when monitoring $n > SP3$)
P06.03 De-energized state OR3 at ' $n > SP3$ ' or ' $n < SP3$ ' Range: 0 .. 3	Without power supply the relays are de-energized (alarm condition). To consider safety aspects of the application, this No-Power condition can be assigned to alarm state $n > SP3$ or $n < SP3$ condition. Setting: 0 : OR3 de-energized at ' $n < SP3$ ' 1 : OR3 de-energized at ' $n > SP3$ ' 2 : OR3 de-energized and latched at ' $n < SP3$ ' 3 : OR3 de-energized and latched at ' $n > SP3$ '
P06.04 Starter effective for SP3 Range: 0 .. 1	The starter function may be effective for each setpoint individually. Thereby it is possible, for instance, to disable a low-speed alarm during the starter phase, whereas a high-speed alarm remains active all the time. Setting: 0 : starter not effective for setpoint SP3 1 : starter effective for setpoint SP3
P06.05 OR3 state at starter condition Range: 0 .. 1	At starter condition, the relay may be forced to state energized or de-energized (if starter function is effective for the alarm). Setting: 0 : OR3 de-energized 1 : OR3 energized
P06.06 OR3 in forced de-energized state at sensor fault condition Range: 0 .. 2	At sensor fault, OR3 may be forced to de-energized state. Setting: 0 : no forced state, state acc. to measured speed 1 : OR3 in de-energized state as if $n > SP3$ (if P06.03 is 1 or 3) 2 : OR3 in de-energized state as if $n < SP3$ (if P06.03 is 0 or 2)

Parameter Group P07.xx Speed Setpoint SP4 and Alarm Output OR4	
Parameter No. Meaning of Parameter Setting Range of Parameter	Description of Parameters and their Settings
P07.00 Speed setpoint SP4 Range: 00001 .. 99999	Speed setpoint SP4 is set in RPM.
P07.01 Hysteresis bandwidth SP4 Range: 00.1 .. 99.9	The hysteresis is the margin between condition "excess" (>) and "no excess" (<), defined by its bandwidth. The hysteresis bandwidth is set as a percentage of the setpoint in steps of 0.1%.
P07.02 Hysteresis position SP4 Range: 0 .. 1	Setting: 0 : hysteresis above SP4 (recommended when monitoring $n < SP4$) 1 : hysteresis below SP4 (recommended when monitoring $n > SP4$)
P07.03 De-energized state OR4 at ' $n > SP4$ ' or ' $n < SP4$ ' Range: 0 .. 3	Without power supply the relays are de-energized (alarm condition). To consider safety aspects of the application, this No-Power condition can be assigned to alarm state $n > SP4$ or $n < SP4$ condition. Setting: 0 : OR4 de-energized at ' $n < SP4$ ' 1 : OR4 de-energized at ' $n > SP4$ ' 2 : OR4 de-energized and latched at ' $n < SP4$ ' 3 : OR4 de-energized and latched at ' $n > SP4$ '
P07.04 Starter effective for SP4 Range: 0 .. 1	The starter function may be effective for each setpoint individually. Thereby it is possible, for instance, to disable a low-speed alarm during the starter phase, whereas a high-speed alarm remains active all the time. Setting: 0 : starter not effective for setpoint SP4 1 : starter effective for setpoint SP4
P07.05 OR4 state at starter condition Range: 0 .. 1	At starter condition, the relay may be forced to state energized or de-energized (if starter function is effective for the alarm). Setting: 0 : OR4 de-energized 1 : OR4 energized
P07.06 OR4 in forced de-energized state at sensor fault condition Range: 0 .. 2	At sensor fault, OR2 may be forced to de-energized state. Setting: 0 : no forced state, state acc. to measured speed 1 : OR4 in de-energized state as if $n > SP4$ (if P07.03 is 1 or 3) 2 : OR4 in de-energized state as if $n < SP4$ (if P07.03 is 0 or 2)

Parameter Group P08.xx Eddy Current sensor input and MPU input	
Parameter No. Meaning of Parameter Setting Range of Parameter	Description of Parameters and their Settings
	Eddy Current sensors must not be operated outside (by manufacturer) specified limits of voltage level and supply current (see also P01.09).
P08.00 Input voltage upper limit Range: 00.0 to 99.9	Input check: input voltage upper limit in xx.x volts
P08.01 Input voltage lower limit Range: 00.0 to 99.9	input voltage lower limit in xx.x volts
P08.02 Current drain upper limit Range: 000 to 999	current drain upper limit in xxx mA
P08.03 Current drain lower limit Range: 000 to 999	current drain lower limit in xxx mA
P08.04 EC and MPU signal input hysteresis Range: 0.0 to 2.5	Signal input hysteresis (sensitivity level) in x.x volts pp Note: with setting 0.0 hysteresis is approx. 70 millivolts pp
P08.05 Reserved	

Parameter Group P09.xx Data Interface	
Parameter No. Meaning of Parameter Setting Range of Parameter	Description of Parameters and their Settings
P09.00 Baud rate Range: 0 .. 4	0 = 300 Baud 1 = 1200 Baud 2 = 9600 Baud 3 = 19200 Baud 4 = 38400 Baud
P09.01 Reserved	

4.1 Default Values

If not specified otherwise, the unit is supplied with default values as listed in the summary of parameters. In the process of installation, the setting of its parameters inevitably must be adapted to the correct values according to its application.

5 Safety Notes for Installation and Operation

5.1 Safety Notes for Installation

This unit has been designed and inspected according to standards DIN EN 61010-1. Observe these instructions and wiring diagrams carefully, to ensure this protection. The installation must be done only by adequately qualified personnel.

5.1.1 General Instructions

Do not open the instrument. Connections and all programming are done from outside. When removing it from its enclosure, however, for whatever reason, make sure that power is switched off.

The instrument may be installed in any position, but not in the immediate neighborhood of interfering sources.

Signal leads must be carefully shielded, and should not be run in bundles with power or relay control leads.

5.1.2 EMI

The unit complies with all relevant regulations, as determined by the Policy of the European Committee for Electrotechnical Standardization (CENELEC), for the Electromagnetic Compatibility (2014/30/EU). Testing and inspection have been performed according to Standards EN 61326-3-2. Thereby, the product meets all requirements to be marked by the CE sign.

Strict observance of these instructions during installation and use is an indispensable precondition hereto.

Specifically, to be observed:

Terminals must be kept off all undue access; power supply and all input and output leads must be protected against voltage interference, higher than specified operation data, and they must be protected against electrostatic discharge.

5.1.3 Safety Notes for Operation

On initial operation of the monitored machine, the operator must ensure proper function of the measurement chains. This includes checking of the correct speed display and the trip release due to a real overspeed condition.

The parameter settings must be documented and protected against unauthorized changes.

5.1.4 Connectors

The connectors must be unplugged and plugged in only if the power supply of the E16521D is off.

5.2 Safety Notes for SIL2 Speed applications

5.2.1 Monitoring the Speed Signal

For full protection against overspeed, the speed signal must be monitored for its plausibility. This can be done via the speed setpoint SP2 (checking for low-speed) or via the analog output. This covers each possible signal fault (fault within the sensor, cable break or short circuit, incorrectly mounted sensor, fault in the barrier D461).

If SP2 is used for plausibility check:

Parameter P04.04 must be set to 1 .

Setpoint SP2 must be set to a speed > 0 .

With machine in operation the measured speed must be above SP2.

If analog output is used for plausibility check:

With machine in operation the value of the analog output must be checked by a system capable of diagnosis and the machine must be set to safe state in case of detected fault.

5.2.2 Use of the Safety Output OR1

OR1 must be used for the safety function.

With a single channel application (one E16521D only), the two contact sets of OR1 must be wired in series.

With triple channel application (three E16521D), the contact sets of the three OR1 may be wired to a 2oo3 circuit.

If the three OR1 outputs are wired to a system capable of diagnosis, it is sufficient to use one contact set only of each OR1.

5.3 Safety Data of E16521D

See document: E16521D-SIL2-SafetyData (B170046_V10_SIL-Datasheet_Braun_E16521D)

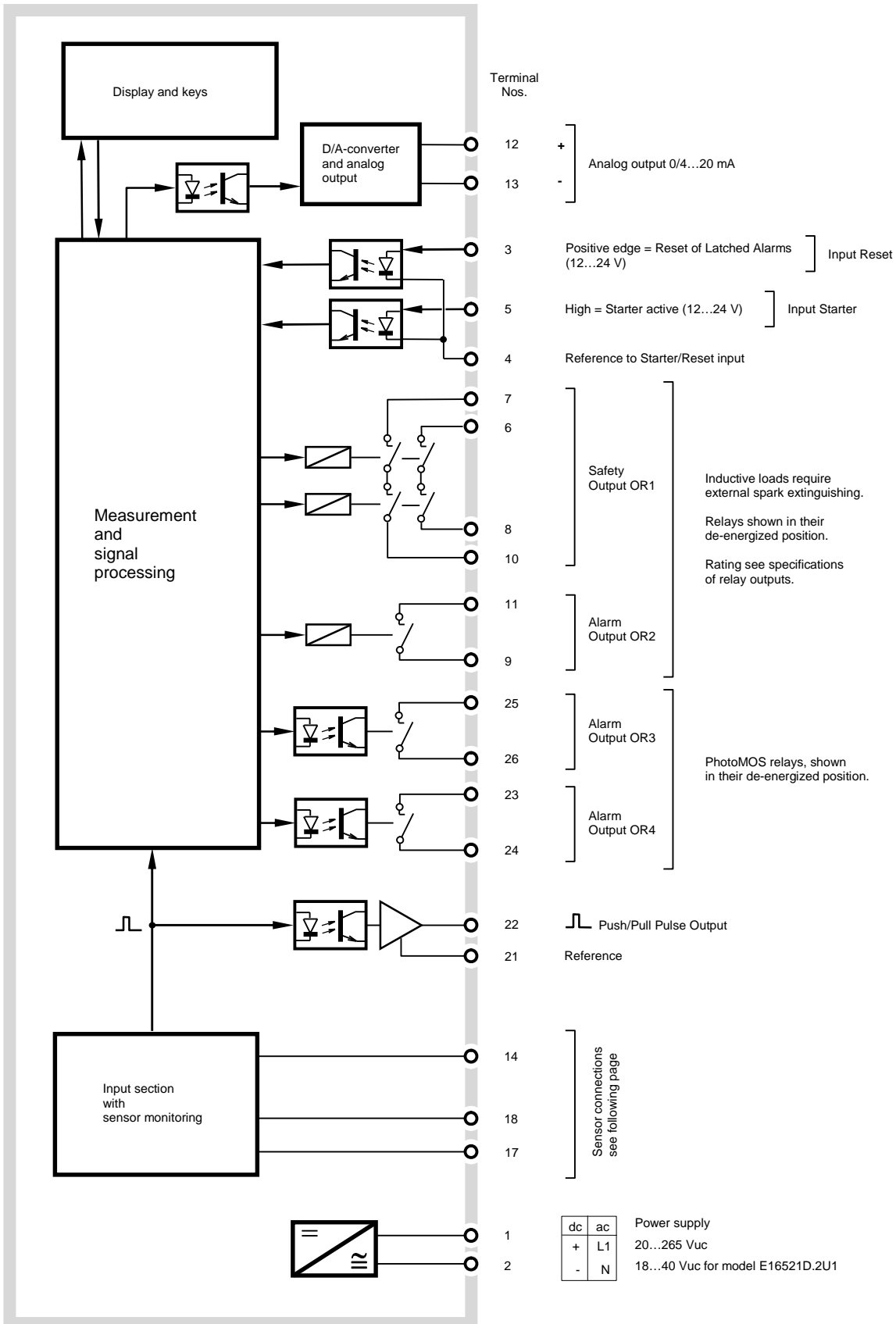

6.2 Connection of Sensors to the Speed Signal Input

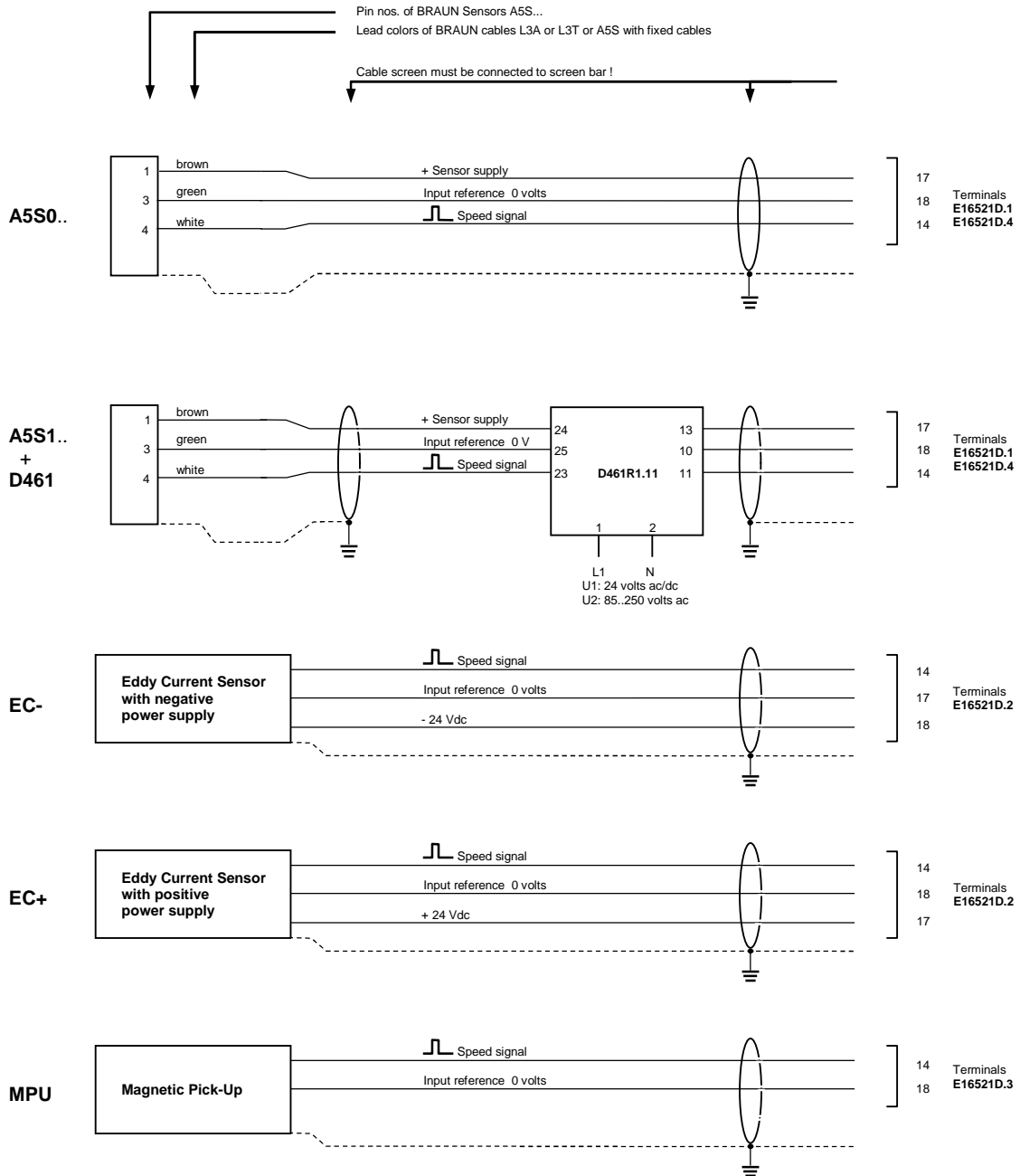

Rev. 00 / 07.2016

6.3 Example for 2oo3 Wiring of Safety Outputs OR1

Other versions of 2oo3 wiring are also possible.

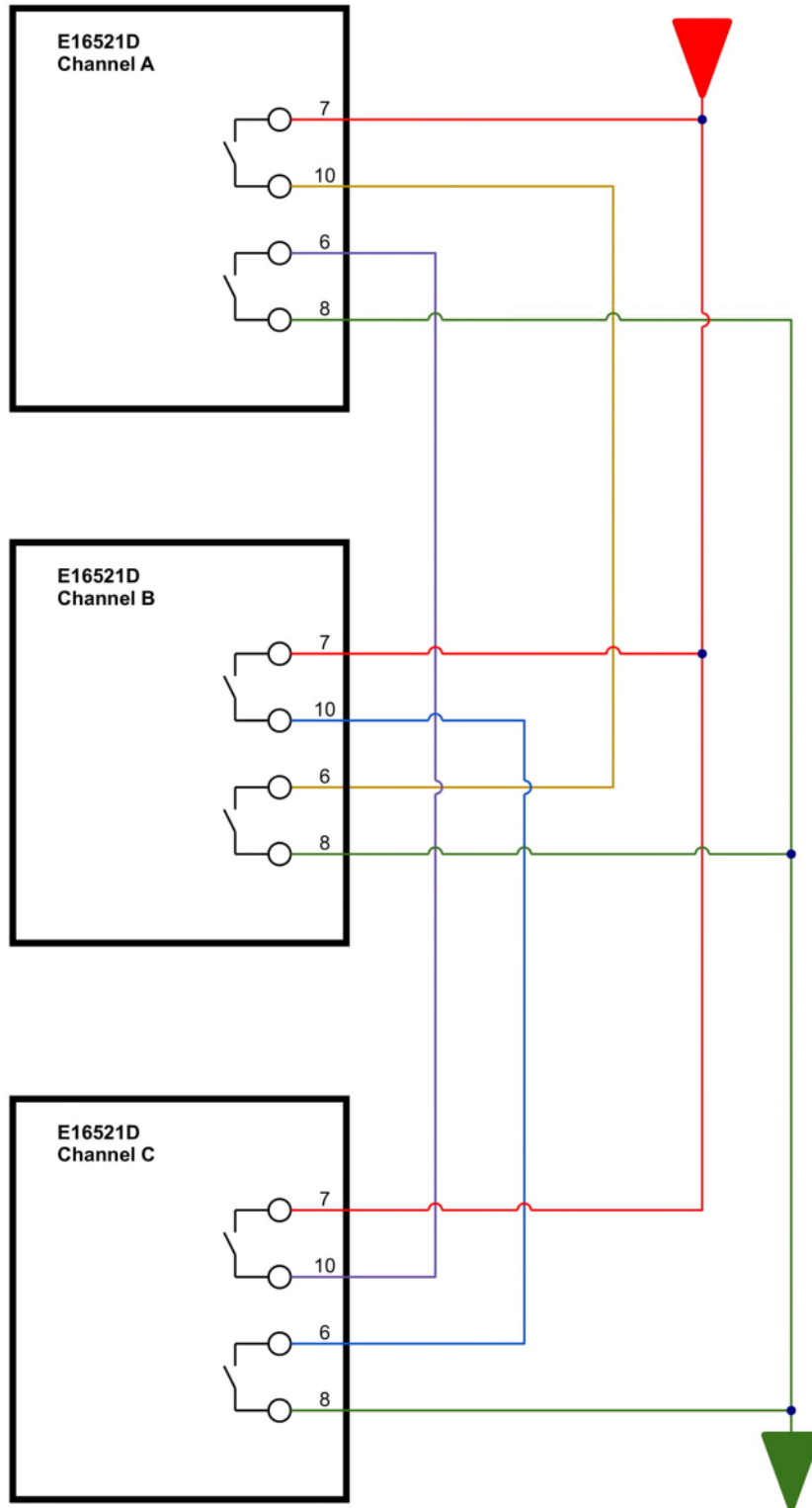

Date	Rev.	Modification
02.04.2016	00	First release
01.07.2016	01	Editorial: E16521D.1 : version for A5S sensors E16521D.2: version for Eddy Current sensors E16521D.3: version for MPU sensors Parameters for Eddy Current (E16521D.2) and MPU sensors (E16521D.3) introduced
21.10.2016	02	Editorial: Wiring diagram modified
06.03.2017	03	Editorial: Chapter 2.16 added
07.03.2017	03	Editorial: Change to Bookmark Format
08.05.2017	04	Editorial: Detailed information (Relay Outputs) at Chapter 1 added
04.07.2017	05	Technical: Parameter P01.07 now is: Setting, if reset is necessary after power up. Modification effective for Serial Nos. exceeding 170630000
30.01.2019	06	Editorial: Chapter 5.2.1 modified
14.01.2020	07	Editorial: Parameter P01.06 now 0 instead of 1. No functional change.
25.01.2020	08	Editorial: Parameter P01.00 and P01.02 = fix value 0
03.02.2020	09	Editorial: Example for 2oo3 wiring of safety output OR1 added
09.11.2020	10	Editorial: Technical Specifications: information for model E16521.D2U1 added. Function diagram: second relay at terminals nos. 7, 6, 8, 9 added.
25.11.2020	11	Editorial: Programming Interface now USB 2.0 instead of RS232. Valid for E16521D with serial nos exceeding 2011250001. Corresponding passages of the individual chapters adapted.
14.01.2021	12	Editorial: Version E16521D.4 (E16521D.1 without display and keys) added
27.07.2023	13	Technical and editorial: See new chapter 2.3.1, valid for units with serial no > 2307210050 respective firmware date D.02.08.23.



Qualität zertifiziert nach ISO 9001

D 71334 Waiblingen-Hegnach
Esslinger Str. 26
Tel.: +49 (0)7151/956230
Fax: +49 (0)7151/956250
E-Mail: info@braun-tacho.de
Internet: www.braun-tacho.de